

NOTES:

- 1. LOCATE EXTRA HANDLE AS SHOWN
- 2. LOCATE PRESSURE RELIEF VALVE AS SHOWN.
- 3. LOCATE CABLE CATCHES AS SHOWN.

ITEM	DESCRIPTION	DRAWING	-133-	-137-	-250	REV.	E.O.A.	DESCRIPTION	BY/DATE	APP.
1	CONTAINER AL 4714-0505 GRN-133		1	-	-					
2	CONTAINER AL 4714-0505 GRN-137		-	1	-			UPDATED BOM	MCH	
3	CONTAINER AL 4714-0505 TAN-250		-	-	1				03/10/22	
4	CUSHION SET 4714-0505	472-M-60-102	1	1	1					
5	KIT AIRTIGHT	MFG-00052-4714AT	1	1	1					
6	KIT CATCH & STRIKE LG W/ HZY	MFG-00003-01	5	-	-					
7	KIT CATCH & STRIKE LG W/ HCB	MFG-00003-04	-	5	5					
8	KIT HINGE HZY	MFG-00010-01	5	-	-					
9	KIT HINGE SSB	MFG-00010-03	-	5	5					
10	KIT HDL INJ (INT) SHORT	MFG-00030	3	3	3					
11	KIT CATCH & STRIKE W/ CABLE LK HCB	MFG-00004-04	-	2	2					
12	KIT CATCH & STRIKE W/ CABLE LK HZY	MFG-00004-01	2	-	-					
13	KIT CABLE HINGE 11" SSP	MFG-00070-11	2	2	2					
14	-	-	-	-	-					
15	-	-	-	-	-					

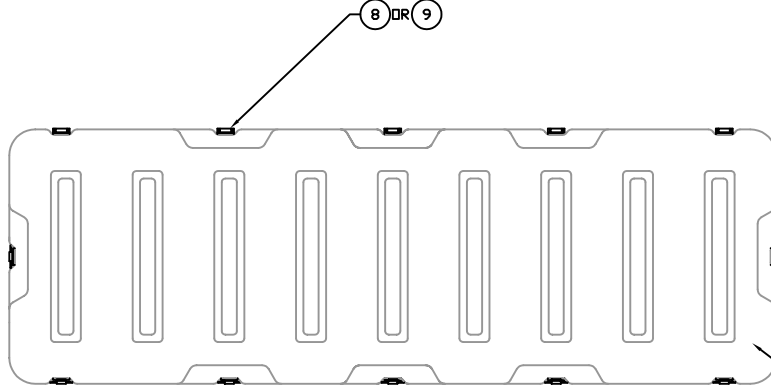

TOP VIEW

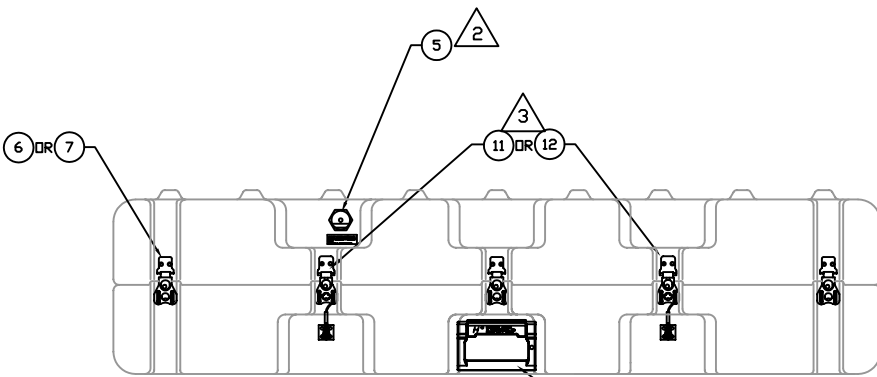

FRONT VIEW

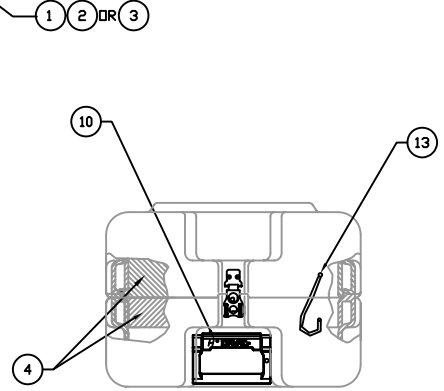

RIGHT SIDE VIEW

REF: 472-M-60-100  
 UNIT: M-60-SINGLE WEAPON CONFIGURATION  
 CONTRACT NO.

NEXT ASSY:	SCALE:	1/8
TOLERANCE UNLESS OTHERWISE SPECIFIED:	FRACTIONAL DECIMAL	
IN:	FRACTIONAL DECIMAL	
1/16 HOLE DIA:	FRACTIONAL DECIMAL	
CHAM:	FRACTIONAL DECIMAL	

**HARDIGG INDUSTRIES, INC.**  
 South Deerfield, Massachusetts 01373

FILE: CNTNR DETAILS  
 AL4714-0505

REV: 111214  
 DATE: 472-M-60-101A  
 SHEET: 1 OF 1

472-M-60-101

